

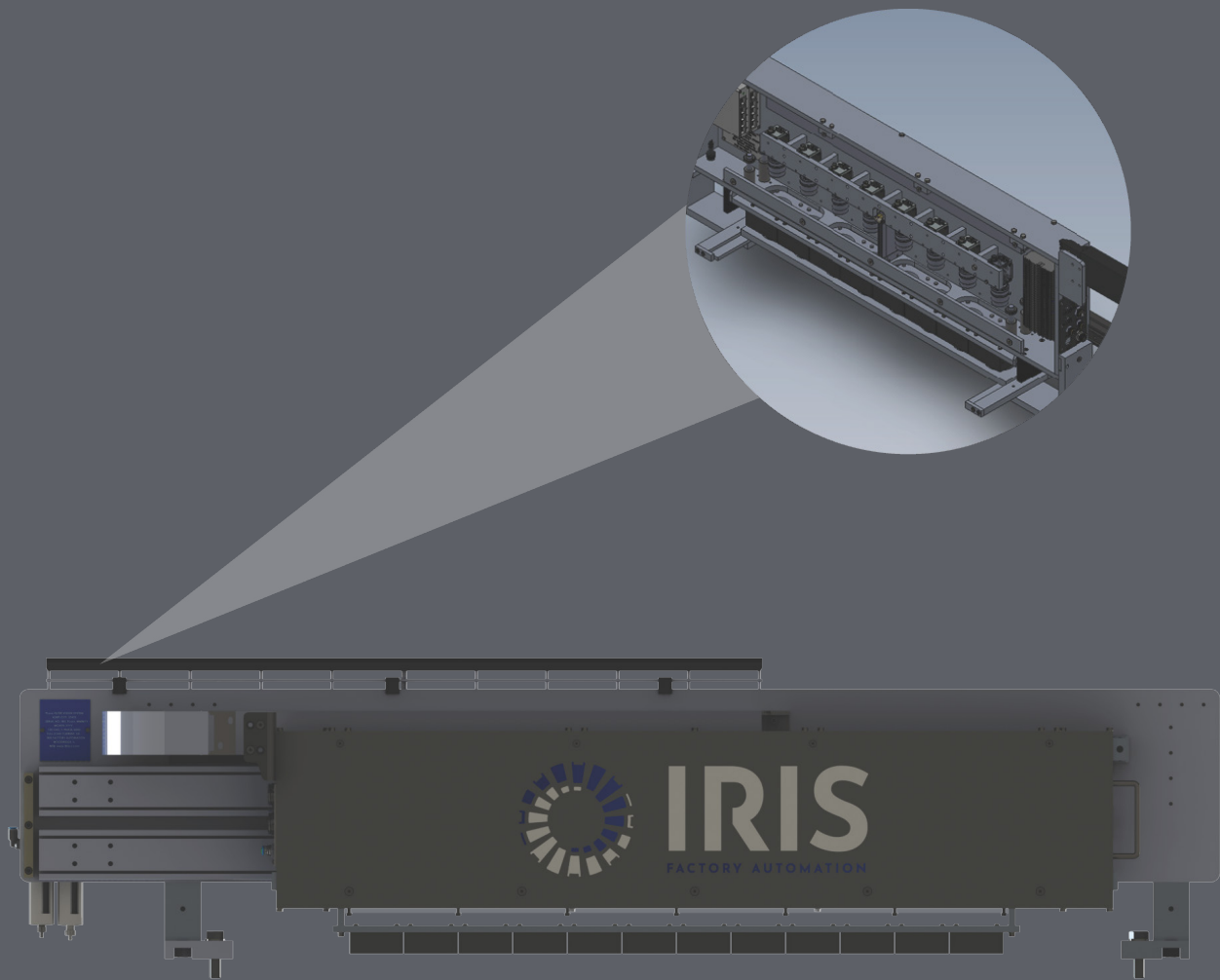

# IRIS

FACTORY AUTOMATION

FILTER VISION SYSTEM



## SYSTEM OVERVIEW

IRIS Filter Vision Systems provide cutting edge Deep Learning vision inspections with reject classification and advanced data analytics for the single-serve coffee industry.

IRIS seamlessly combines quality control systems and real-time data analytics, empowering rapid machine issue identification and delivering crucial information for enhanced equipment maintenance.

# System Features

## Real-Time Data Analysis Tools

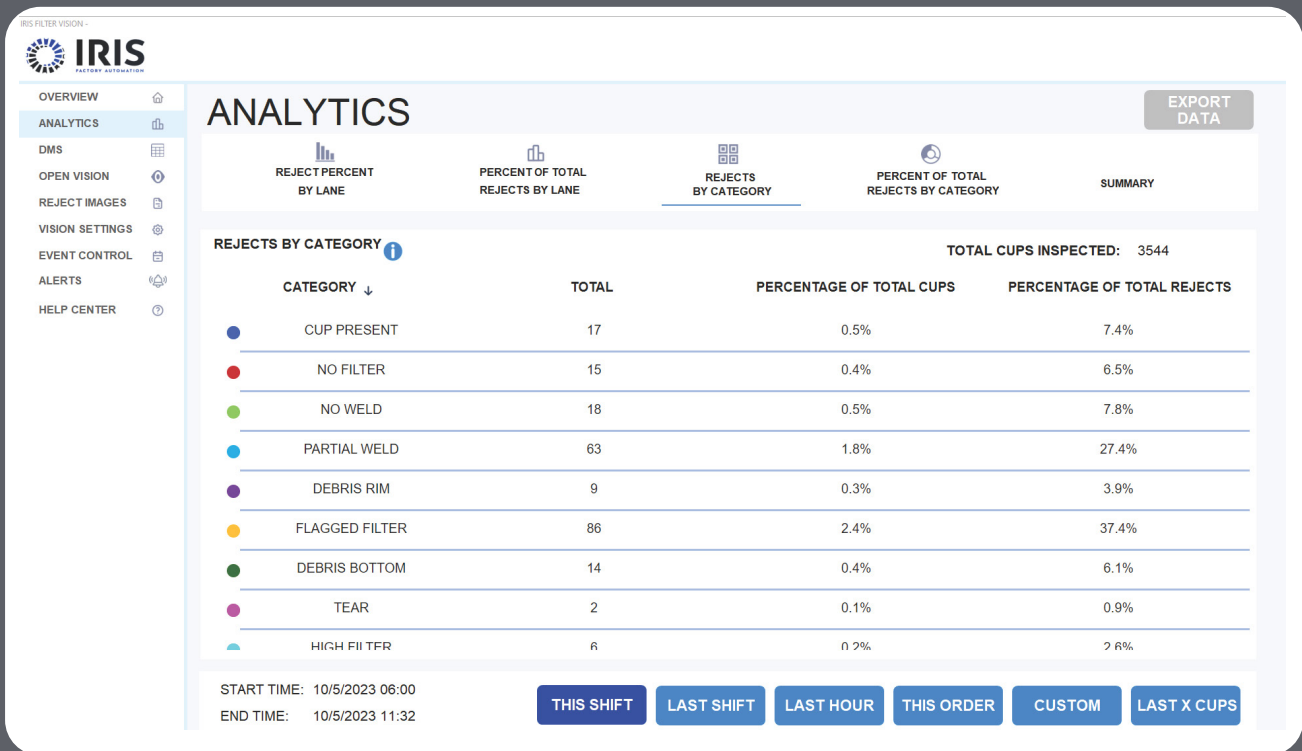

### Current & past performance

The IRIS FVS Dashboard allows users to quickly review current and past performance of equipment.

### Identify sources of defects quickly

Quickly identify sources of defects by lane and defect classifications

START TIME: 10/5/2023 06:00  
END TIME: 10/5/2023 11:32

THIS SHIFT

LAST SHIFT

LAST HOUR

THIS ORDER

CUSTOM

LAST X CUPS

### Historical Data

By utilizing customizable time inputs, easily review historical images and inspection data.

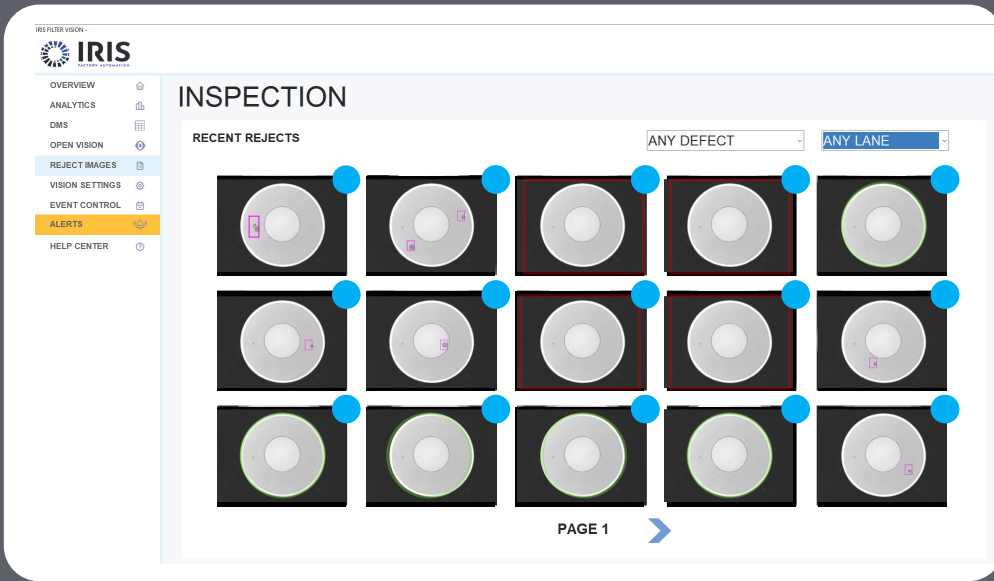

## Diagnostic Data

The IRIS Filter Vision System allows users to quickly review reject images to help diagnose equipment.

## One-Click Sorting

Easily sort viewing options on system conditions by lane and/or defect classification.

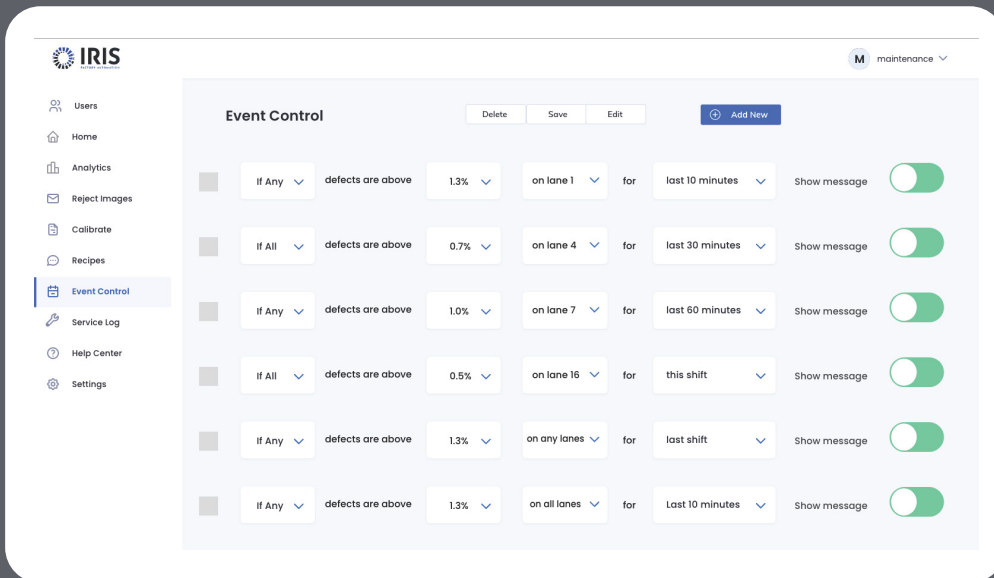
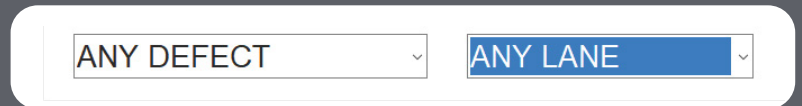

## Customizable Alert Settings and Quick-Viewing

Set alerts based on pre-set thresholds and view current trending alarms.

# Deep Learning Vision Inspection

with Defect Classification

## TRADITIONAL VISION INSPECTION VS AI

- Reject Rate with Traditional Vision Tools
- Reject Rate Using AI Vision Tools

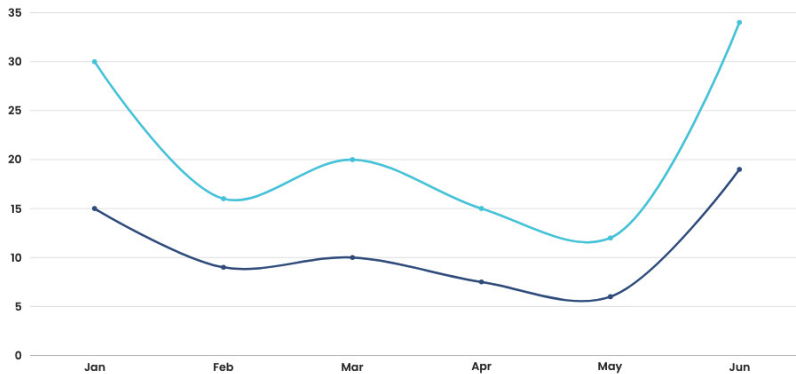

# 50% ↓

## reduction in false rejects

AI-Based IRIS Vision systems can reduce the overall reject rate by an average of 50%.

## Root cause analysis

The IRIS FVS Vision systems is able to leverage the use of deep learning algorithms to detect the smallest variation based on predefined classifications customizable to your manufacturing requirements.

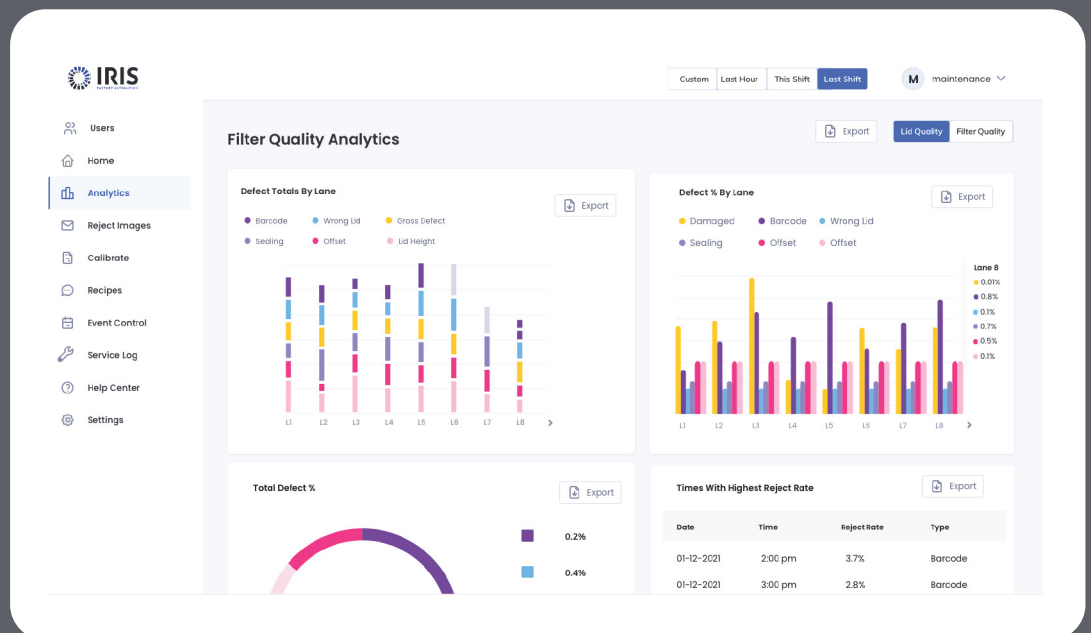

## Subtle Defect Detection

Using deep learning algorithms, IRIS FVS allows for inspection of more subtle defects than traditional vision tools.

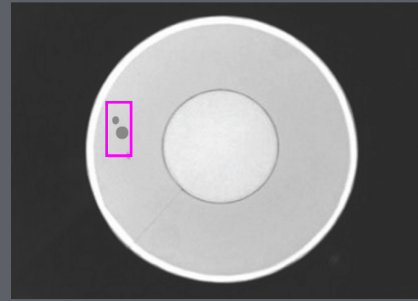

Tear in filter



## Application Fits

The IRIS Filter Vision System is better suited for standard variation in raw materials such as filter paper.

## Common Defect Types

- No cup / filter / weld
- Partial or skip welds
- Flagged / Folded-in filters
- High filter
- Holes/ tears in filter
- Debris / foreign material



## High Speed Inspection

The IRIS Filter Vision system is capable of inspecting 800 pods / minute and does not require stationary pods for inspection.

**Small Footprint** IRIS FVS only requires 4.7" of space in Filter forming / filler equipment.

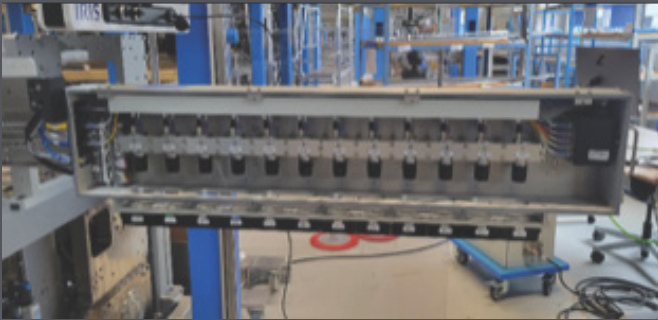
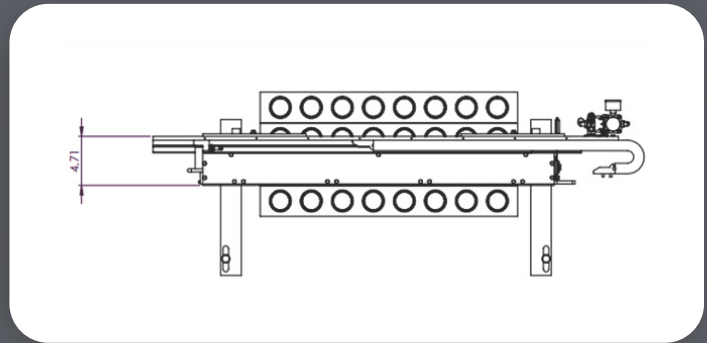

### Accessible Design

The IRIS Filter Vision System comes equip with telescopic rails allow for full system extension outside of machine. Specifically designed for as little adjustments as possible, ideal for maintenance activities such as cleaning and calibration.

### Stand alone HMI

Alternative HMI and Electrical Panel mounting options are available for optimal monitoring of the system from anywhere.



# Automated Vision Systems for Enhanced Precision and Efficiency

The Full Line of Vision Offerings



## Filter Vision System

- Real-time data analysis
- Deep learning vision classification with vision inspection
- High speed inspection
- Small footprint
- Accessible design
- Stand alone HMI kiosk for system control monitoring



## Barcode Scanning System

- Advanced user interface
- High speed processing classification with vision inspection
- Low profile design
- Recipe based lighting control
- Intuitive user experience



## Overwatch Vision System

- Traditional Automated Inspection
- AI-Based automation inspection
- Track and trace
- Small footprint
- Predictive analytics



# Let's talk solutions



phone: **(630) 634-7700**

website: **[irisfactoryautomation.com](http://irisfactoryautomation.com)**

email: **[sales@iriscs.com](mailto:sales@iriscs.com)**